

<b>4-TINE SQUARE BALE STABBER</b>	<b>Number of tines</b>	<b>Hydraulic or Manual (Fixed)</b>	<b>Bushing/Tine Size (inch)</b>	<b>Tine length (inch-useable)</b>	<b>Number of bales</b>	<b>Square Bale Size</b>
HC133	4	H	1 <sup>3</sup> / <sub>8</sub>	33	2	3x3
HC133E	4	H	1 <sup>3</sup> / <sub>8</sub>	33	3	3x3
HC233E	4	H	1 <sup>3</sup> / <sub>4</sub>	33	3	3x3
HC233E-WL	4	H	1 <sup>3</sup> / <sub>4</sub>	33	3	3x3
HC243	4	H	1 <sup>3</sup> / <sub>4</sub>	43	2	3x4
HC243E	4	H	1 <sup>3</sup> / <sub>4</sub>	43	2-3	4x4-3x4
HC243E-WL	4	H	1 <sup>3</sup> / <sub>4</sub>	43	2-3	4x4-3x4
M3C133*	3	M	1 <sup>3</sup> / <sub>8</sub>	33	1	3x3
M3C233*	3	M	1 <sup>3</sup> / <sub>4</sub>	33	1	3x3
M3C243*	3	M	1 <sup>3</sup> / <sub>4</sub>	43	1	4x4
MC133	4	M	1 <sup>3</sup> / <sub>8</sub>	33	2	3x3
MC133E	4	M	1 <sup>3</sup> / <sub>8</sub>	33	3	3x3
MC233	4	M	1 <sup>3</sup> / <sub>4</sub>	33	2	3x3
MC233E	4	M	1 <sup>3</sup> / <sub>4</sub>	33	3	3x3
MC233E-WL	4	M	1 <sup>3</sup> / <sub>4</sub>	33	3	3x3
MC243	4	M	1 <sup>3</sup> / <sub>4</sub>	43	2	3x4
MC243E	4	M	1 <sup>3</sup> / <sub>4</sub>	43	2-3	4x4-3x4
MC243E-WL	4	M	1 <sup>3</sup> / <sub>4</sub>	43	2-3	4x4-3x4

(H) Hydraulic Push-off, w/ Cylinders & Hoses

(M) Fixed No Push-off

(E) Top Extension

(WL) Additional Bracing for Wheel Loader

Available in Black and Green

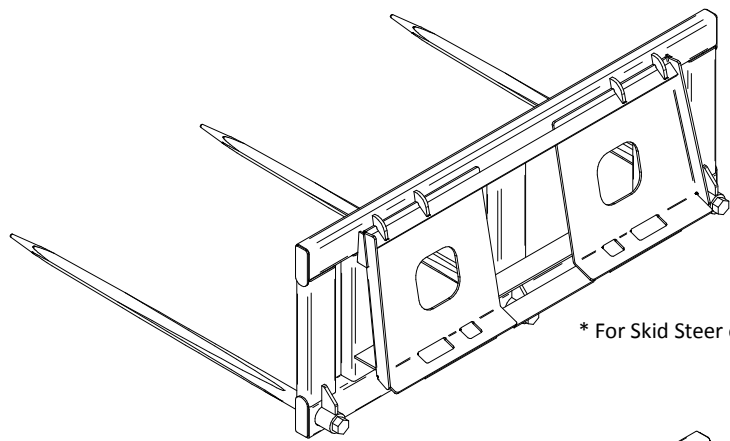

\* For Skid Steer only

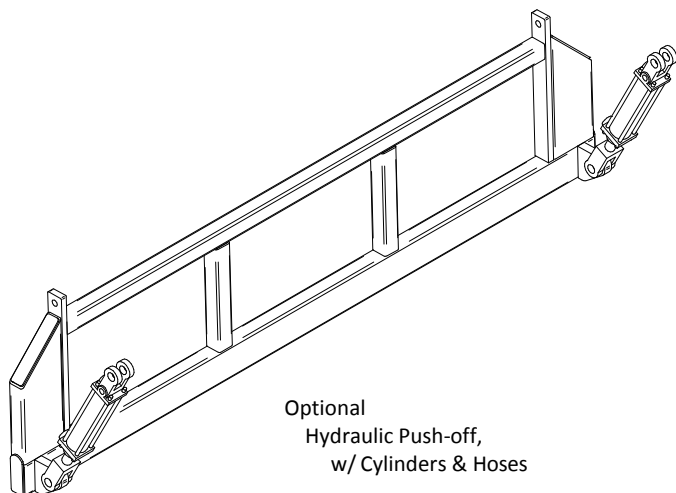
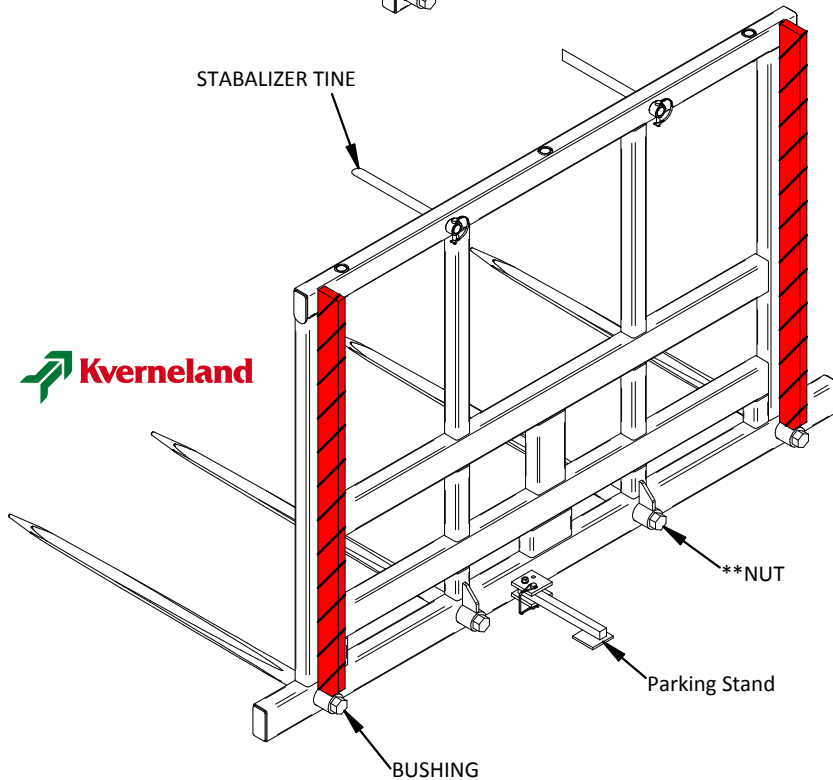

Optional Hydraulic Push-off, w/ Cylinders & Hoses

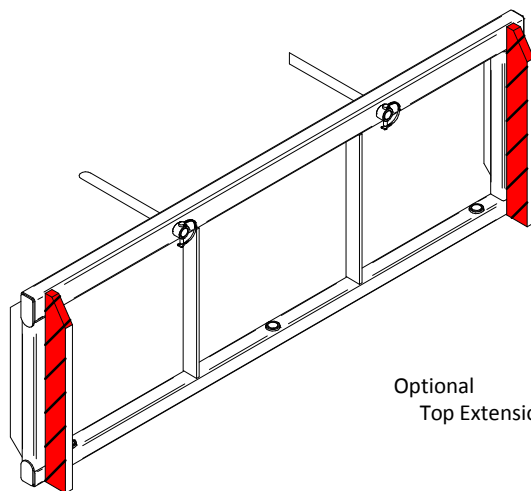

Optional Top Extension

\*\*TIGHTENING TORQUE FOR NUT = 290-325 FT. LBS. (C1)  
TIGHTENING TORQUE FOR NUT = 470-505 FT. LBS. (C2)



1301 S. SD Hwy. 37 - Parkston, SD 57366  
Phone: (605) 928-7951 - Fax: (605) 928-7952  
Toll Free: 800-658-4703 - email: mds@sanitel.net

MANUFACTURING Co., INC. [www.mdsmf.com](http://www.mdsmf.com)